



**ligne roset®**

depuis 1860

Discover the new Ligne Roset collection, whose creations pay homage to the noblest of materials in an exquisite expression of French craftsmanship and expertise.

A poetic and artistic invitation to the ever-more-vital pleasures of coming together and living well. Let your inspiration be your guide and make full use of our latest products to reimagine your interior.

Briord, Rémi Bouhaniche



Desk with top and drawer in black-stained ash veneered MDF and structure in satin black lacquered steel.

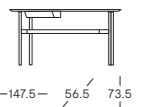



Grand Angle, Marie Christine Dorner

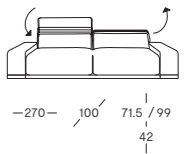
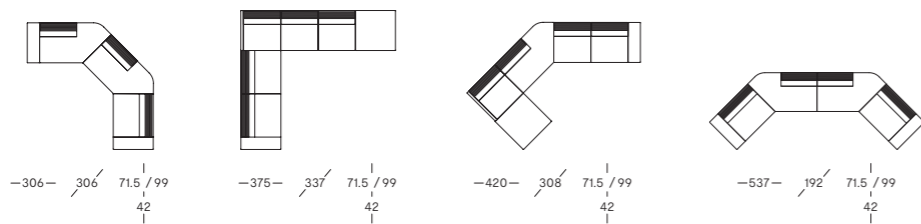

A deep, multifaceted modular settee with an articulated headrest.  
Available in leather, fabric or microfibre.

Telen, Christian Werner



Telen is evocative of Japanese zen gardens, its design of piled-up pebbles. Delicately rounded and feminine, this settee is exquisitely decorative.

Orientali rug, Lotis occasional tables, Ruffette suspended lights.



Hémicycle, Philippe Nigro



Collaboration with the Mobilier National. A numbered, "heritage" Piece which may be made up in leather, fabric or microfibre, in a bicolour or bi-material interpretation.

Astrée floor lamp & Mallea low table.

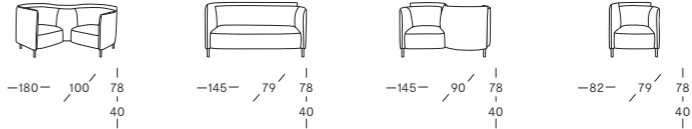



Canalounge, settee, 1-arm settee, armchair and footstool.  
Fully upholstered base. Available in leather, fabric or  
Microfibre, in a bicolour or bi-material interpretation.

Agosto rug, Felia floor lamp, Intervalle low table.

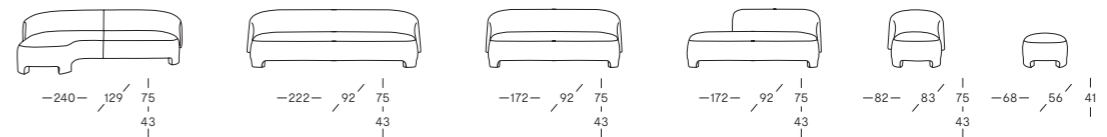

Intervalle, Guillaume Delvigne



Dining table and low table in solid wood, available in American walnut, European walnut, black or grey-stained European walnut, burnt-effect oak, natural oak, black-stained oak, cherry or whitened oak.

Hood lamp lights, Alando sideboard, Losange rug, Rays suspended lights.

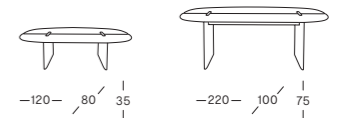





Sideboard with three flap doors in dark walnut with structure in bleu nuit and either a tubular metal frame or a low base. Also available with two flap doors and three drawers. The collection is completed by a dark walnut desk.

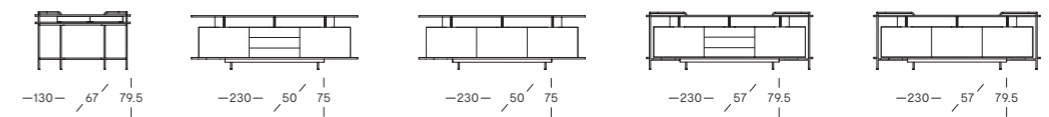

Ennéa, Vincent Tordjman



Selvans, Christian Werner

Ennéa rests on one or two bases in solid natural or black-stained wood, depending on the size of the top. The top is available in ceramic stoneware, dark walnut or fused glass, with an optional Lazy Susan.

The marriage of grooved dark walnut and ceramic stoneware gives Selvans great elegance and an air of classic luxury. The top is in a choice of white marble-effect or gloss black ceramic stoneware.

Noctambule rug, Rufflette suspended light, Kinoko table lamp.

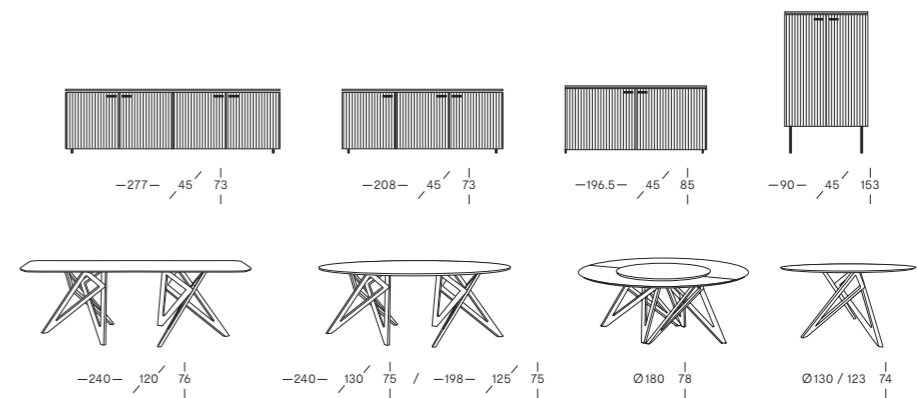

Évisa, Philippe Nigro



Bed with integral upholstered sleep platform and HR Bultex foam suspension. Choice of two leg heights : 10 or 15 cm. Structure of headboard in metal mesh and tubing, covered in HR Bultex foam. Headboard and surround quilted with polyester.

Valmy armchairs, Nodum occasional table, Nimbe mirrors, Parabole chest of drawers, Passepartout bedside tables.

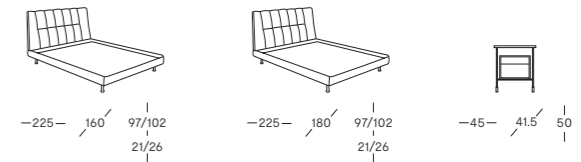

Valmy, Ramy Fischler



Armchair and carver chair with base in black lacquered steel, natural beech or anthracite-stained beech. Available in all fabrics, microfibres and leathers.

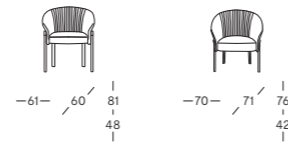

Nimbe mirror, Marie-Aurore Stiker-Metral.  
Roseau vases, Noé Duchaufour-Lawrance.  
Asata candle holders, Obvision.

Find our full collection of accessories on [ligne-roset.com](http://ligne-roset.com)



[ligne-roset.com](http://ligne-roset.com)